

Woodsman's Thong Manual

Patriots' Path Council, B.S.A.

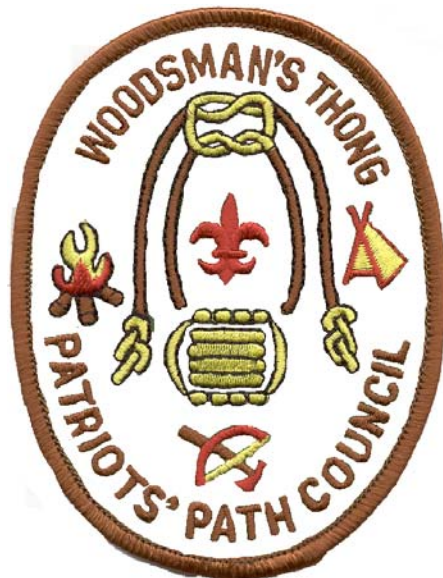

Foil Cooking

Compiled by:

Nick Fantini

FOLDING FRYING PAN

Here's an Idea for a folding frying pan --amazingly light and easy to carry. Pull a wire hanger from its triangular shape into a square, as shown. Bend the hook down for a handle. Double a section of aluminum foil around the wire square, folding the remaining three sides under securely. While cooking, the food will depress the center of foil a bit, so hot fat, cake batter, gravy, and other liquids won't run off. This frying pan can be placed on three or four small flat rocks, with the coal fire between them. Each person can make his own frying pan, and can use it for a plate!



HOT DINNER PACKAGE

While we're talking about cooking with aluminum foil, you might like to try the "Hot Dinner Package" idea. This is a complete meal in foil, and can be made up at home in advance --ready to cook as soon as the fire has burned down to coals.

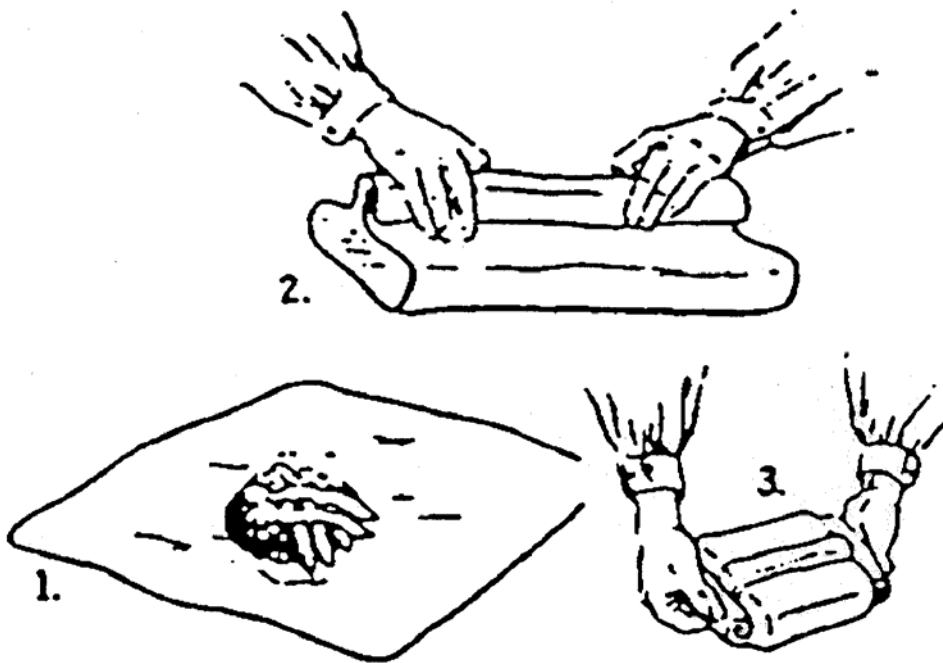

As the sketch shows, lay a flat raw hamburger patty, on a square foot of doubled or of extra thickness, aluminum foil. Layover it a few thin slices of raw potato, some slivers of carrot, and a few slices of onion. Flavor as desired, such as with a bit of butter, and a shake of salt and pepper. Pick up the opposite sides of the foil, and by doubling them over together, fold the foil down compactly. Then, do the same with the other sides. Each package is an individual serving, so each portion of food can be as much or as little as desired.

When meal time arrives, preparation of a delicious hot dinner is quick and easy. Make a small fire, and when it has burned down to coals, put the packages dinner in or near the coal (hamburger side down) for 10 or 15 minutes, depending on how big the package is and how well done the meat should be. Rake a few coals over the top of the packet as well. When the meat is cooked, poke out the package from the fire; unwrap it, and use the Alcoa Wrap as a plate. The foil, incidentally, cools quickly, and will be no hotter than the food inside.

Variations in foil cooking are almost endless, but these ideas may serve as examples to show how easy outdoor cooking really is. Foil cooking is fun -- and there are few things to carry and to wash! When the papers and refuse are burned or buried, and the fire is safely doused with water, our chores are over, and we have enjoyed a delicious meal -- the easy way.

MAKING UTENSILS FROM COAT HANGERS

TWISTED FOIL CUP

The twisted foil cup handle, previously mentioned, can be improved upon, too, if we want to bother with something a bit handier. Cut the hook part from a wire coat hanger and straighten the wire, using a strong pair or wire-cutting pliers, such as "Sportmates", which many sportsmen habitually carry. Bend the middle part of the long wire around a can of the right size, to form a loop. Twist the wire two or three times to make the hoop secure. Now, using the

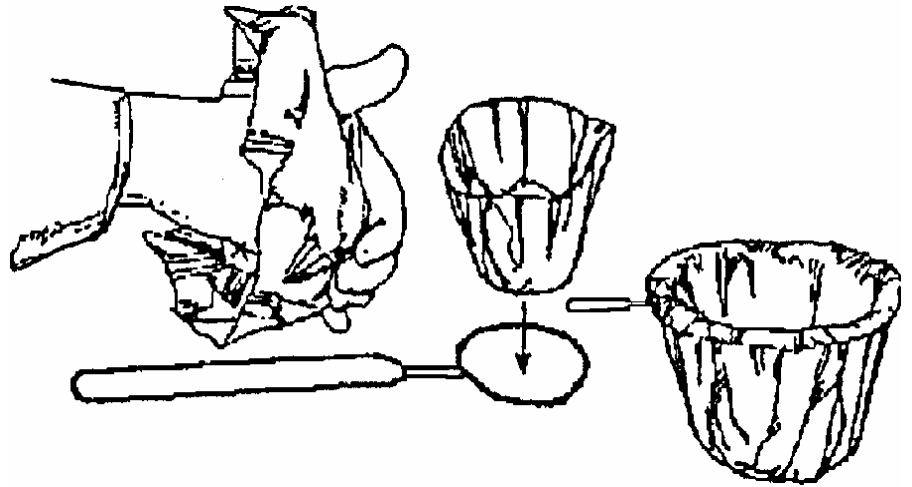

"Sportmates" pliers, bend the remaining wire into a handle, as the illustration indicates. This "hoop rim and handle" is extremely light and easy to carry.

To use this little gadget, form a foil cup around a can of the same size (or a bit smaller) and insert the cup into the rim. Roll the foil edges down evenly over the rim, this will make a very serviceable cup or saucepan. If we punch some small holes in the bottom, the cup will be transformed into a strainer!

EGG POACHER

Too many outdoor cooks use too much grease in their cooking --thus, often times making the food less tasty and less digestible. For breakfasts, for example, the rule seems to be to fry the eggs. Why not use the cup rim to poach them?

To make an egg poacher, merely lay a small sheet of Alcoa Wrap over the cup rim; depress the center

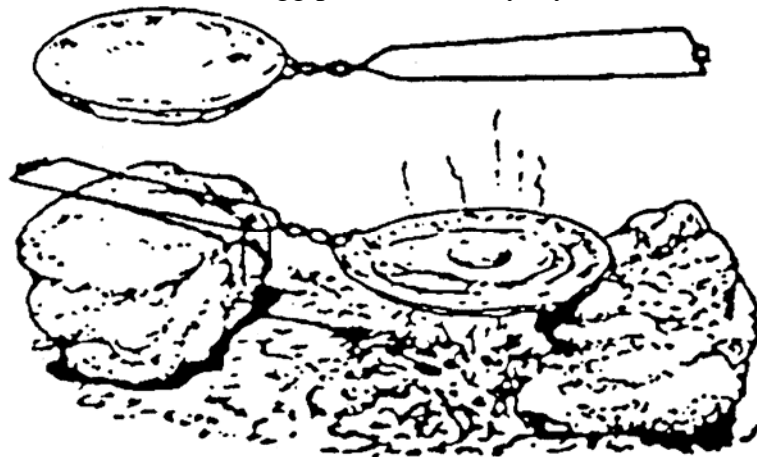

only half an inch or so, and fold the foil edges securely underneath the rim. Put a small amount of water in this little pan, and when it is boiling, drop an egg into it. The egg will poach nicely over the fire and will come out as round and even as if it had been cooked in a fancy restaurant! Poached eggs on toast make delicious breakfasts out of doors. When the egg is cooked, pour off nearly all of the remaining water and add a bit of butter, salt, and pepper. Slide the egg onto the toast on its Alcoa Wrap plate, and see if the recipe isn't as good as it sounds!

REFLECTOR OVEN PROCEDURES

A **Reflector Oven** is used for roasting or baking. Heat from the open fire is reflected onto the food from the back panel and ground layer of foil. Materials Needed:

- 2 22" Straight Sticks
- 2 y Sticks Measuring 20" below the 'y'
- 1 Roll Aluminum Wrap Heavy-duty 18" wide
- 1 Baking Rack
- 5 Flat Rocks
- 2 Pot Holders

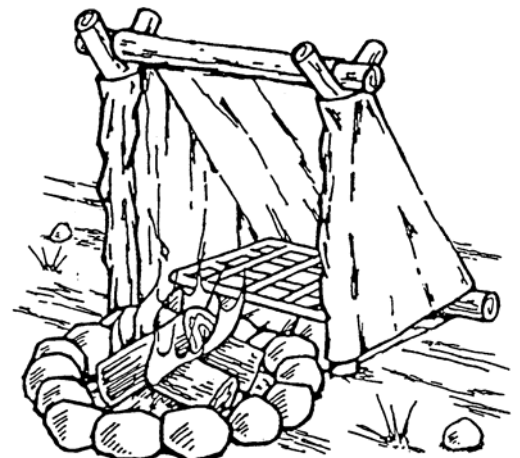

1. Insert two y shaped sticks, about 18 inches apart, firmly into the ground at the edge of the fire ring, and close enough so that the heat of the fire is reflected into the oven.

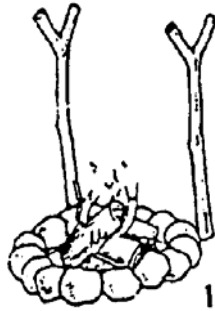

2. Remove Reynolds Wrap from the box. Wrap end around a straight 22 inch stick, and place across the y shaped openings.

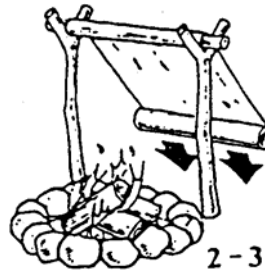

3. Unroll foil sheet down toward the ground at a 45 degree angle. Lay another 22 inch stick at ground level to hold the foil secure. Bring remaining foil forward, allowing enough space on the foil behind the y shaped sticks to hold a baking rack. Tear off the sheet.

4. Place baking rack on 4 rocks in oven.

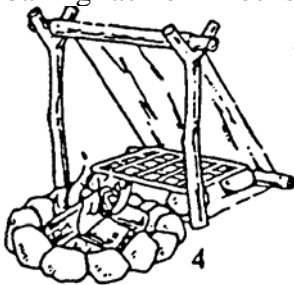

5. For side panel, wrap 18" edge of foil to y stick. Exlend to center back of oven. Tear off sheet, repeat with other y stick.

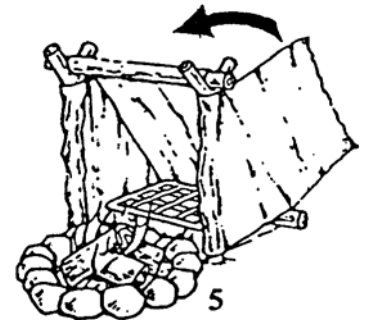

6. Fold sheets together starting at upper corner and folding toward back of oven.

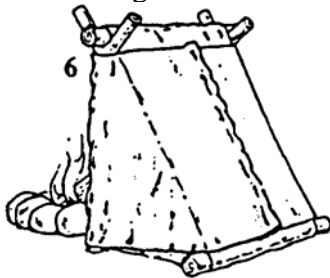

7. To use, open oven by unfolding one side panel at back of oven, secure again quickly to prevent heat loss.

BAKING PAN, BAKING SHEET OR DRIP PAN

1. Use 2 sheets or Heavy Duty Aluminum Wrap – 6 inches longer and 6 inches wider Than the desired size or pan. Fold in all edges 1-1/2 to 2 inches.

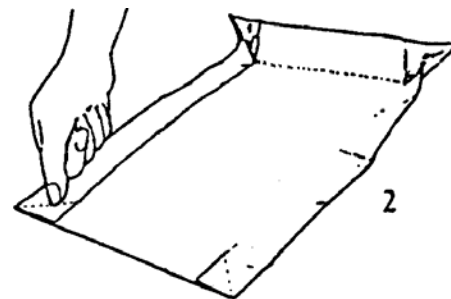
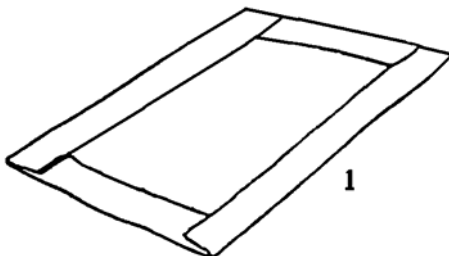

2. Score corners.

3. Fold again forming 1-1/2 to 2-inch sides and miter corners against sides or pan.

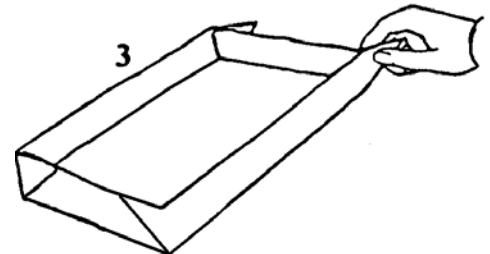

Baking Pan: Use 3 sheets or heavy duty aluminum wrap to form a pan for batter foods such as cakes, brownies and cornbread. For added stability, place pan on metal grill rack before filling with batter.

SAUCE POT AND MIXING/SERVING BOWL

1. Mold three layers of heavy duty aluminum wrap around a one gallon drinking cooler or end of a log to form the desired size.

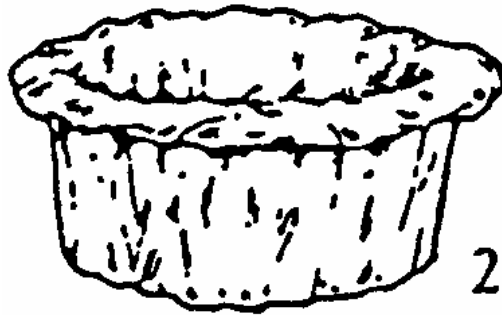
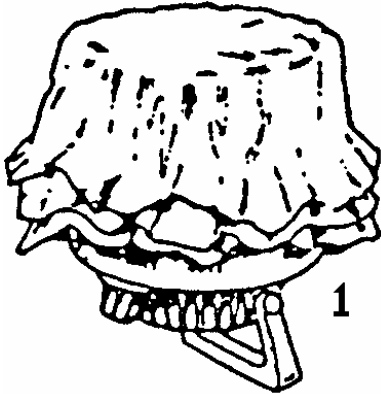

2. Remove: crimp down edges to form a tight rim.

3. To use, place on metal rack supported by rocks over hot embers.



CAUTION: Use pot holders to remove saucepot from rack.

COAT HANGER GRIDDLE

1. Pull bottom of coat hanger into a square of wire. Bend the hook downward to make a handle

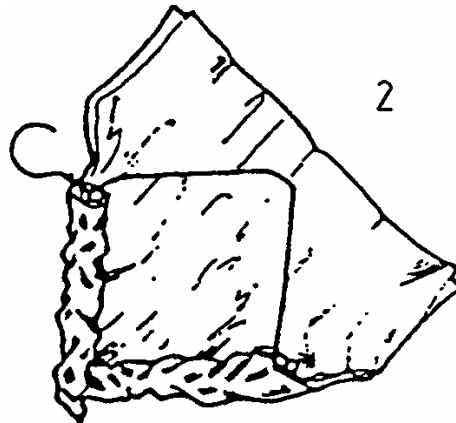
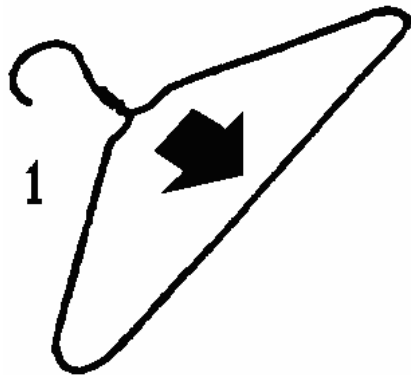

2. Center hanger on 2 sheets of heavy Duty aluminum wrap $1\frac{1}{2}$ times the size of square. Roll each side toward wire rims, crimping until secure.

3. Turn griddle over; depress the center slightly to form a well to hold food.

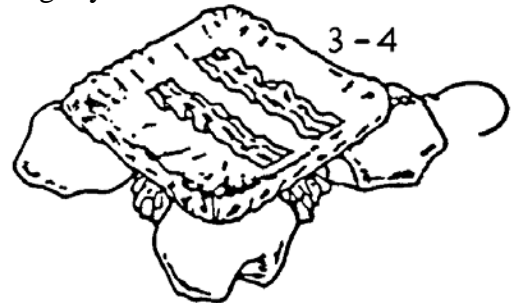

4. To use, prop griddle on rocks over hot embers. CAUTION: Always use pot holders when handling hot griddle.

BUNDLE WRAP

1. Place food in center of a sheet of heavy duty aluminum foil large enough to permit adequate wrapping.

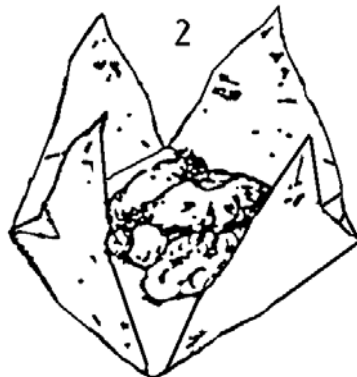

2. Bring 4 corners of foil up together in a pyramid shape.

3. Fold the open edges together in a series of locked folds, allowing for heat circulation and expansion.



4. Place bundle flat on embers to prevent leakage or on grill rack over embers. Use long-handled longs to rotate bundles.

FORKED STICK FRYING PAN

1. Use a forked stick with prongs wide enough to contain food. Center stick on 2 sheets of heavy duty aluminum wrap, double the width of fork opening.

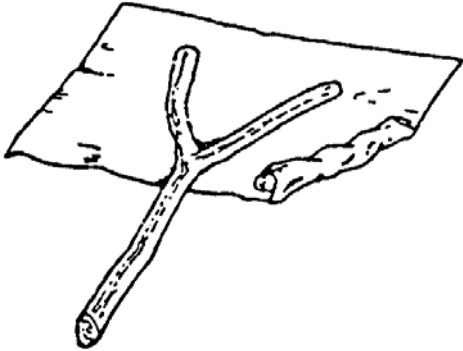

2

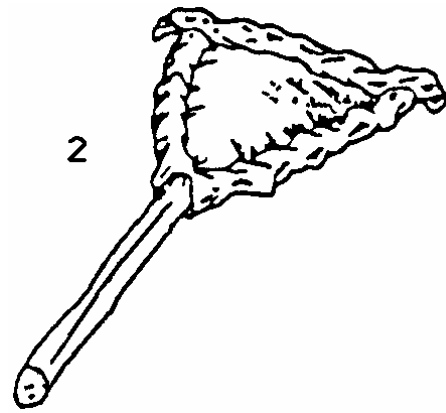

2. Starting at bottom corners, roll foil diagonally toward fork; crimp securely around each side of fork. Roll top edge down.

3. Turn forked stick over: depress the center slightly to form a well to hold food and to keep liquids from running off. Roll a sheet of heavy duty aluminum wrap around neck of pan handle to protect stick from fire.

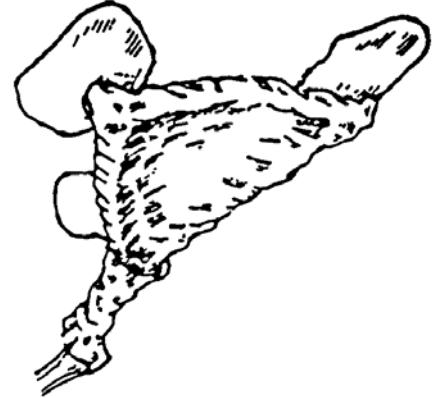

4. To use, sheets of heavy duty aluminum wrap frying pan can be propped over hot embers by resting on rocks.

BACON AND EGGS

Place bacon slices in frying pan. Cook over hot embers 10 to 20 minutes or until bacon is crisp; remove bacon. Break eggs in hot grease. Cook 5 to 10 minute or until doneness.

FISH

Lightly grease frying pan; heat over hot embers for several minutes; Dip fish in cornmeal; place in pan. Cook over hot embers 20 minutes, turning several times, or until fish flakes easily. Cooking times varies with the size of fish.

CARDBOARD REFLECTOR OVEN

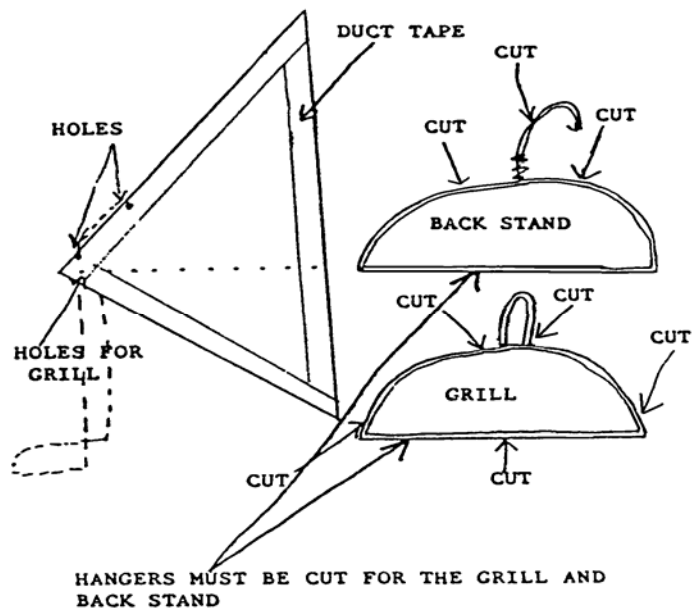
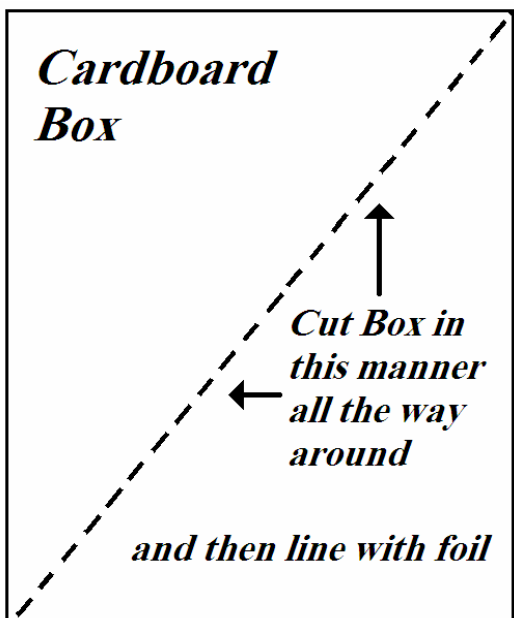
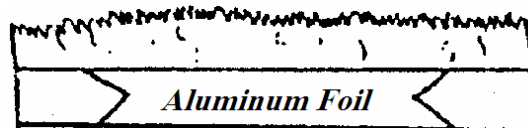

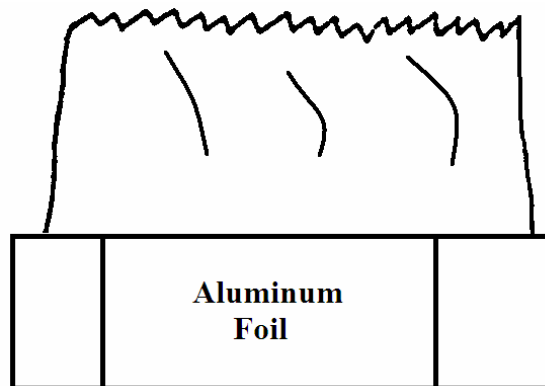
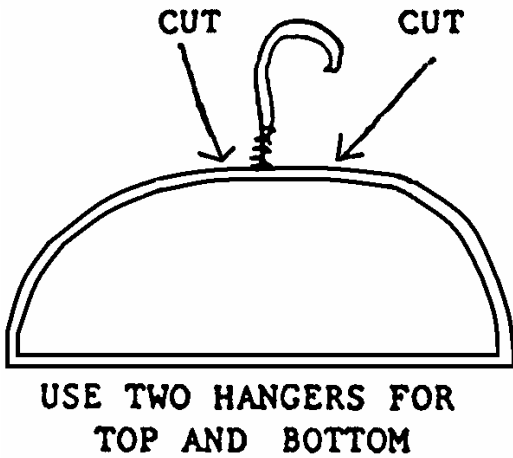
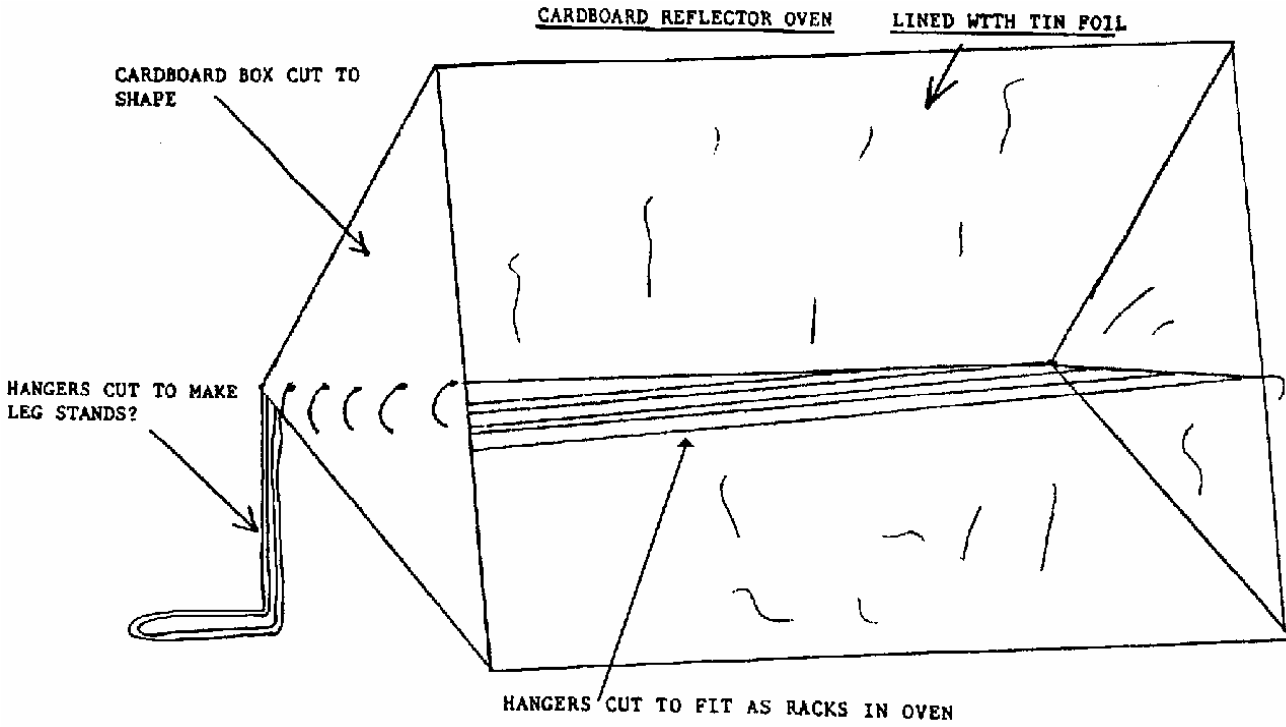
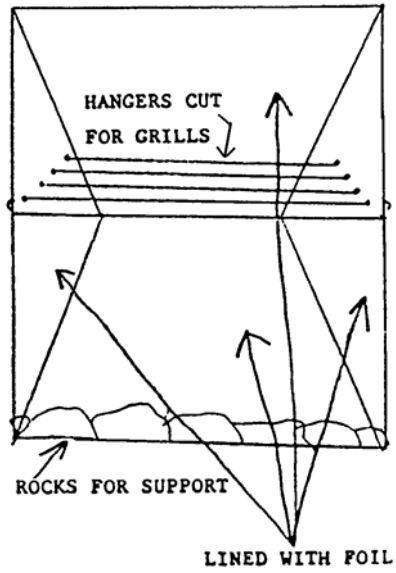
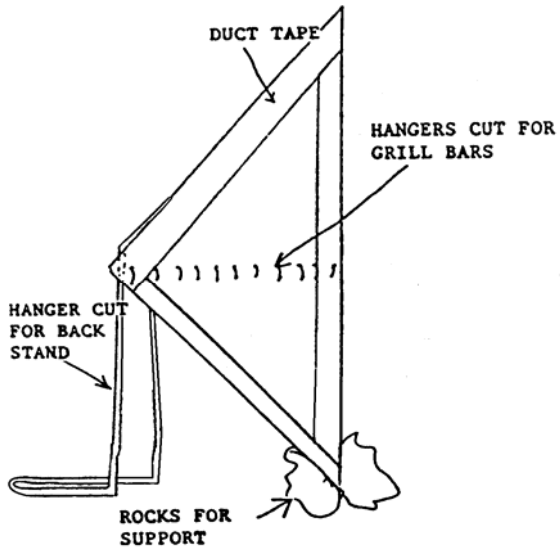

TWIST WITH PLYERS

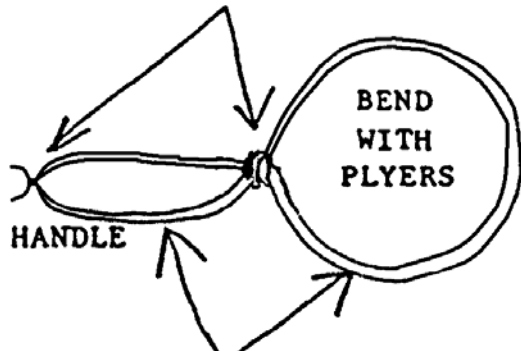

BEND WITH PLYERS

HANDLE

FOLD FOIL OVER THE CIRCLE IN HANGER

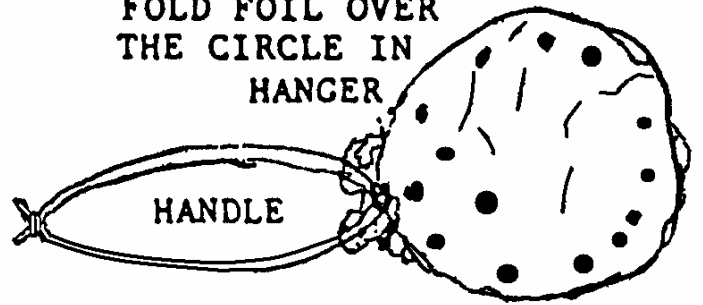

HANDLE

VENT HOLES TO ALLOW HEAT IN

USE PLYERS TO SHAPE FOR BOTTOM SECTION



MAKE TOP SECTION

FOR TOP SECTION

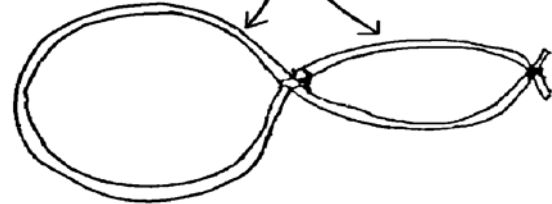

SAME SIZE AS BOTTOM

MAKE SURE THAT BOTH TOP AND BOTTOM OF TOASTER ARE THE SAME SIZE

USE A CAN OR LOG TO SHAPE FOIL TO SIZE

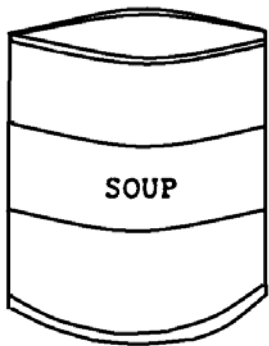

FOLD OVER HANGER TO FORM THE TOP SECTION



VENT HOLES ALLOWING STEAM TO ESCAPE



TOP SECTION

ENGLISH MUFFIN PIZZA



BOTTOM SECTION

LOG CAN BE MADE LARGER OR SMALLER IF NEEDED

LOG FOR A REST

FIRE

CHICKEN UNDER AN UMBRELLA

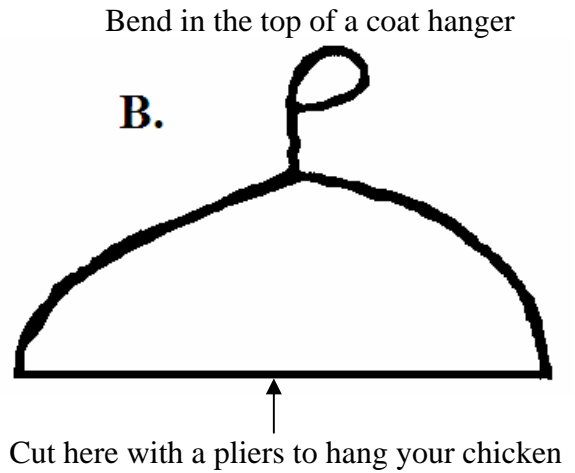
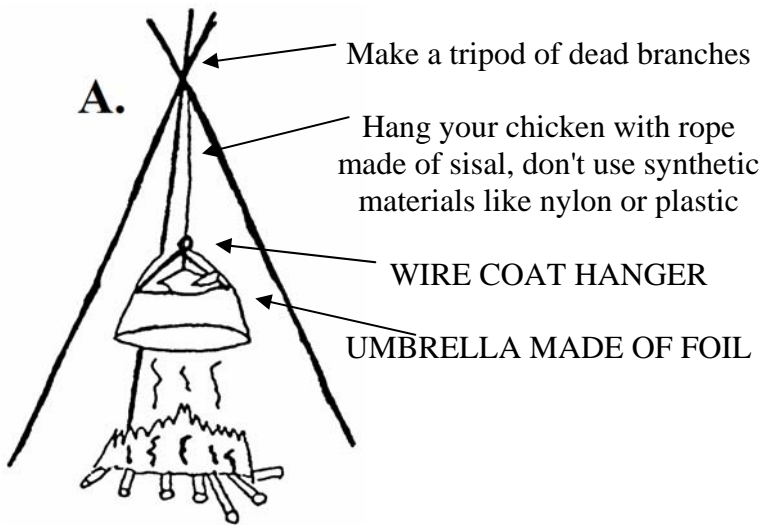

Make a twist to hold the chicken

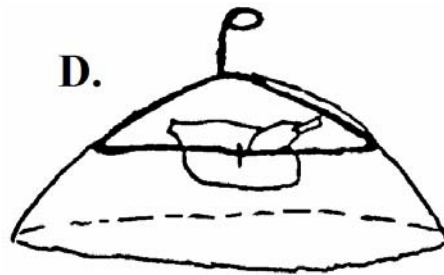
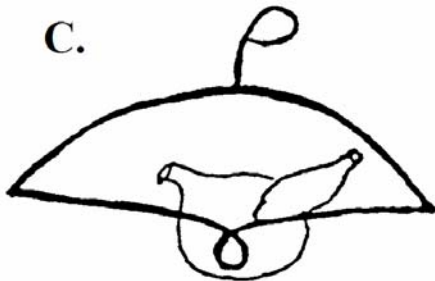

Place foil over the top of the hanger to make your umbrella, hang it from the tripod and the chicken will baste itself

E. Make sure that the foil umbrella is not touching the chicken, heat must pass around the chicken.

F. Put some potatoes wrapped in foil in the fire, sit back, take it easy, while your dinner cooks!

FOIL HEN

Take a long sheet of aluminum foil and fold it in half, longer pieces for larger projects.

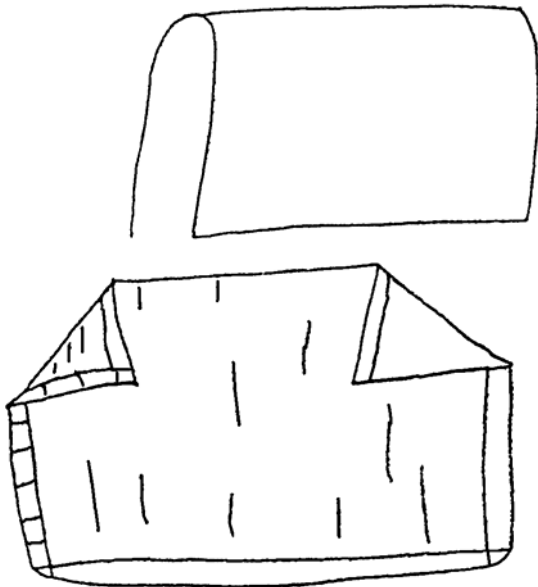

Fold in the top corners, as in the diagram.

Fold in the open side with a lock fold.

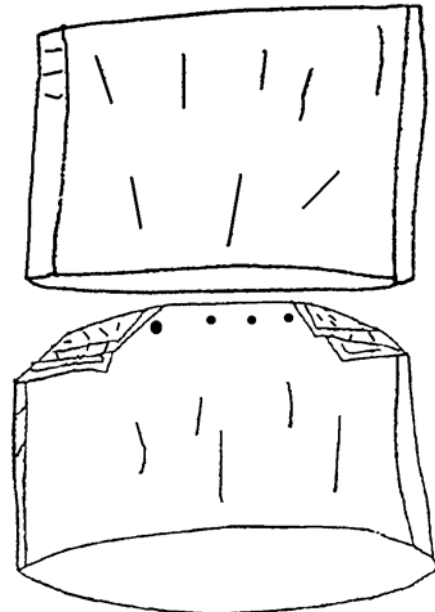

Fold the ends one more time and punch some holes in the top to let out steam.

Place your "Hen" over the item you are cooking on the grill or campfire coals. It will keep the heat in and around your food like an oven.

FOIL OVEN

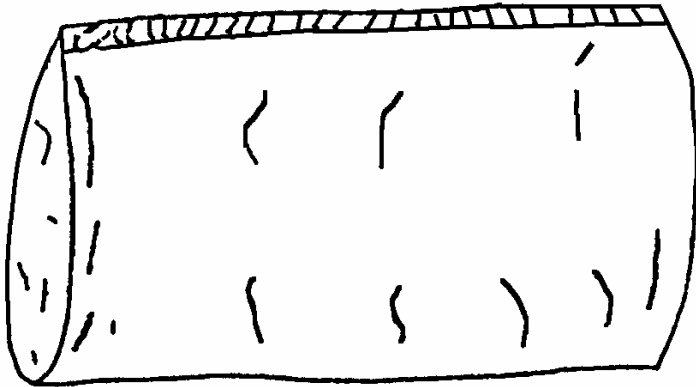

Fold a long sheet of aluminum foil in half. Then fold and lock the top and crinkle it shut.

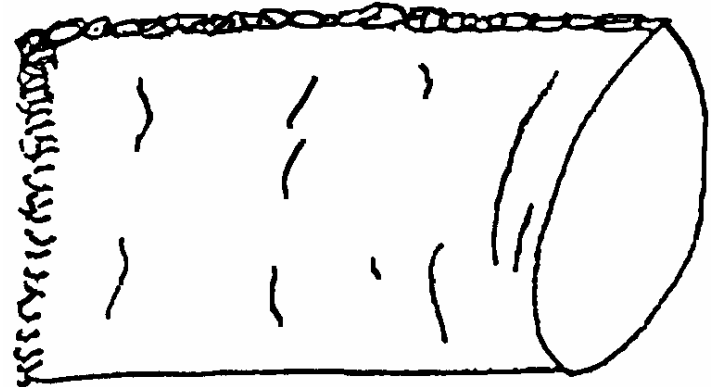

Next, fold and crinkle one of the short ends to make an envelope.

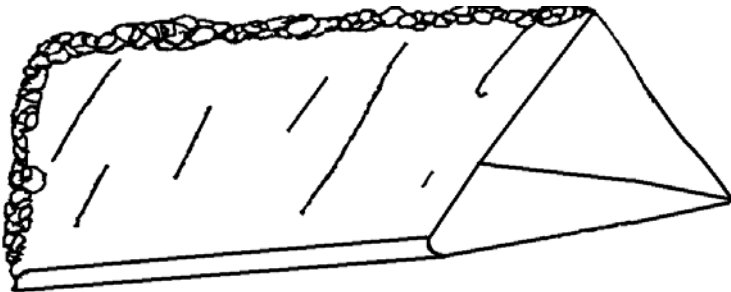

Put your hand inside and flatten the lower side to make a triangular opening.

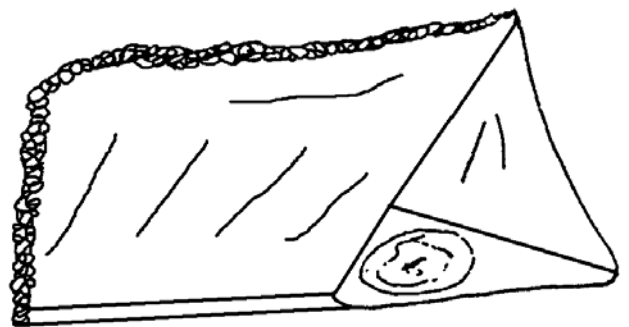

Place the items you want to bake inside on the flat bottom and put your oven on the heat.

It's better to put your oven off to one side of the fire or coals to prevent burning.

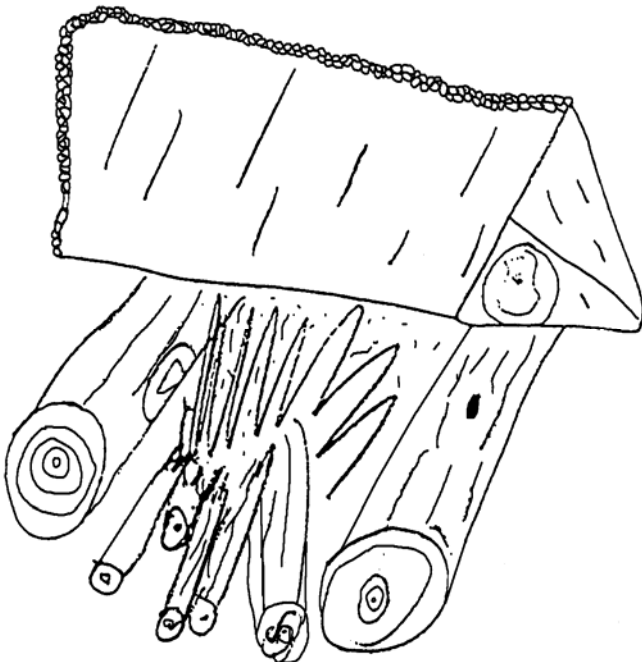

You can use this oven for foods like:

- ❖ English muffin pizzas
- ❖ bread
- ❖ biscuits
- ❖ muffins
- ❖ pastries
- ❖ hot sandwiches

FOIL CUP

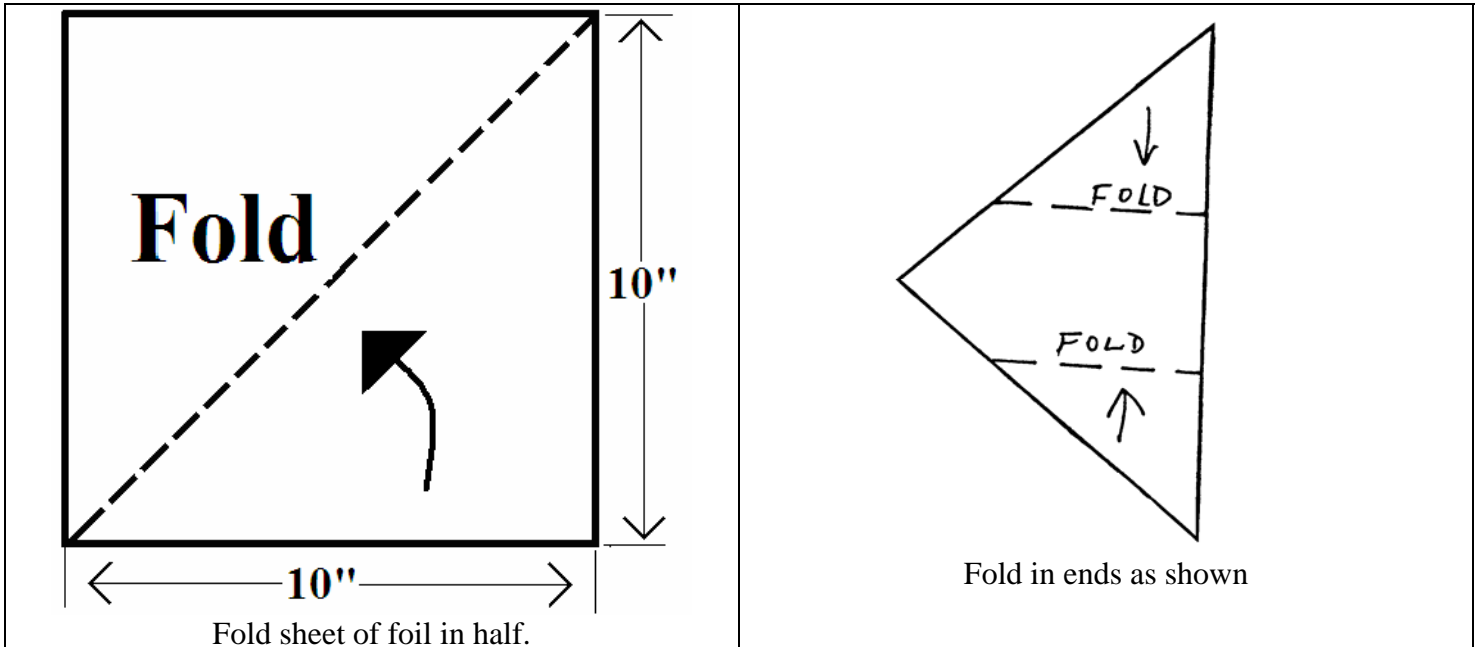

Fold sheet of foil in half.

Fold in ends as shown

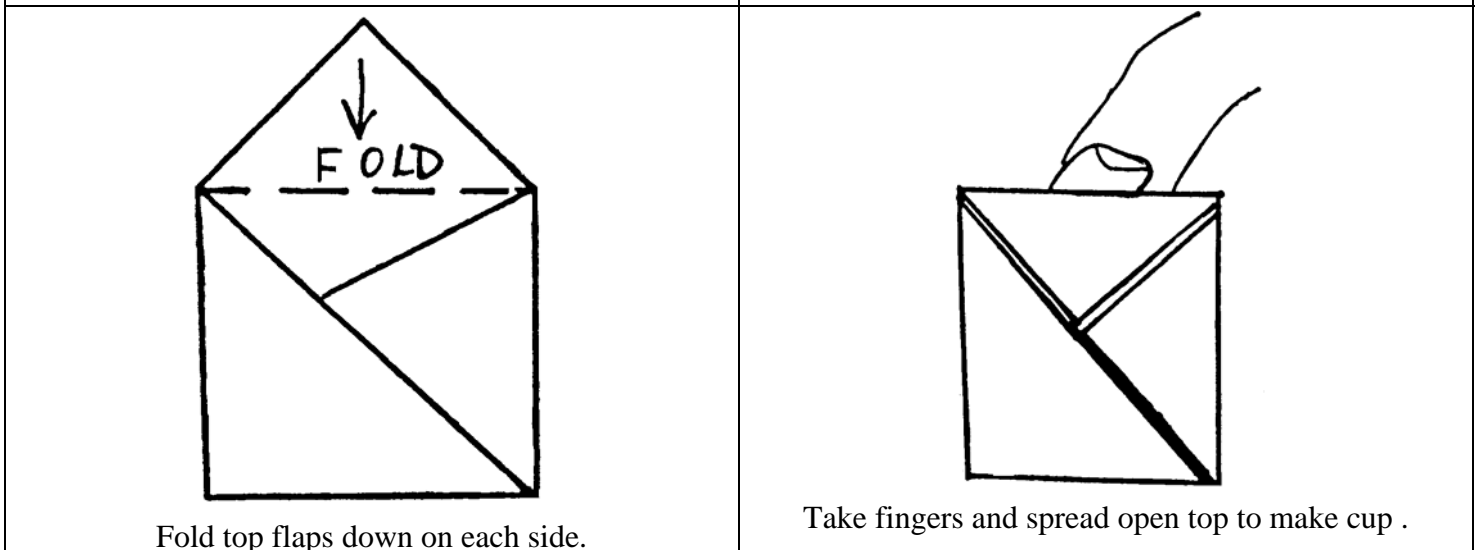

Fold top flaps down on each side.

Take fingers and spread open top to make cup .

WINTER COOKING FIRE

To keep fire off wet ground, make your firelay on a sheet of heavy-duty aluminum foil. For easy lighting, light a candle stub with a match and use that in the center of your firelay. It won't blow out as quickly as a match in a brisk wind.

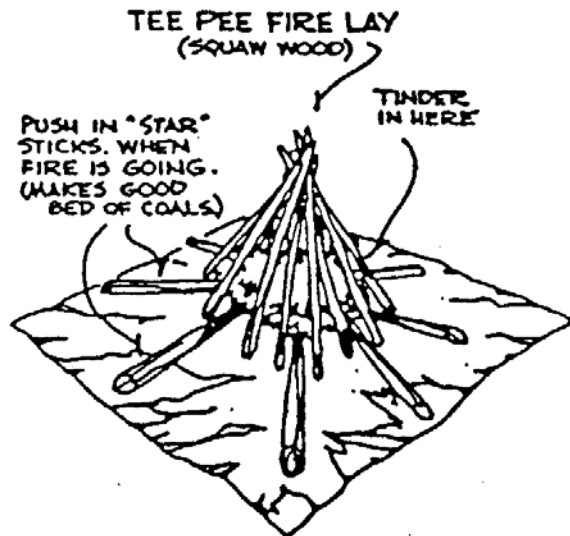

USING A PIECE OF 18" x 36" WIDE FOIL
YOU CAN MAKE ...

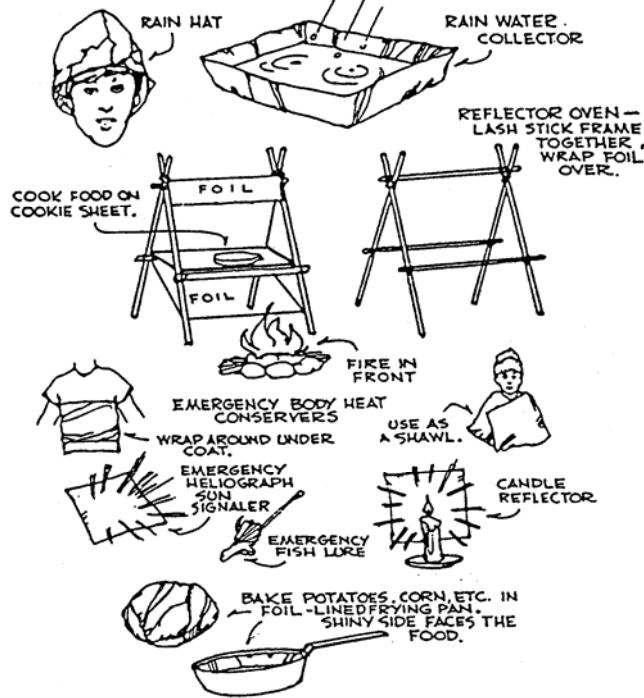

VERSATILE FOIL.

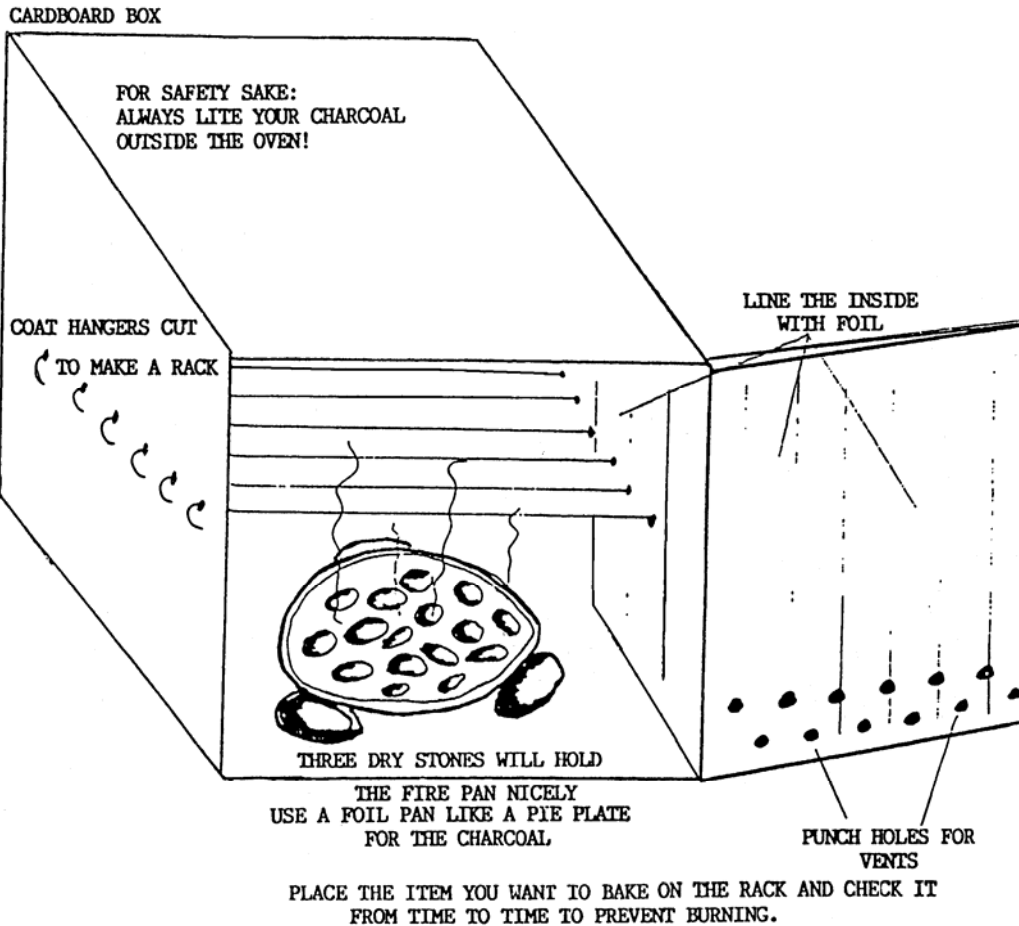

HOBO STOVE



Cut hanger to size with pliers

Place cut hangers from one hole to another to form an X

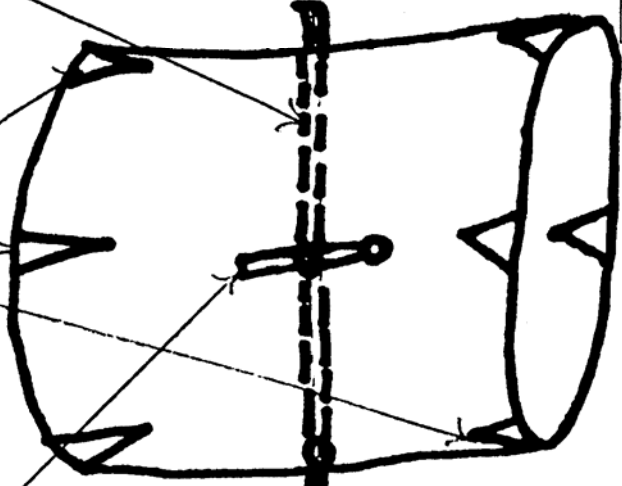

Punch in holes for ventilation with a can opener

Insert hangers for grate support

Fold cut ends under with pliers all the way around

Punch in holes for grate holders made from hangers

Punch holes in it with a nail & hammer on a piece of wood

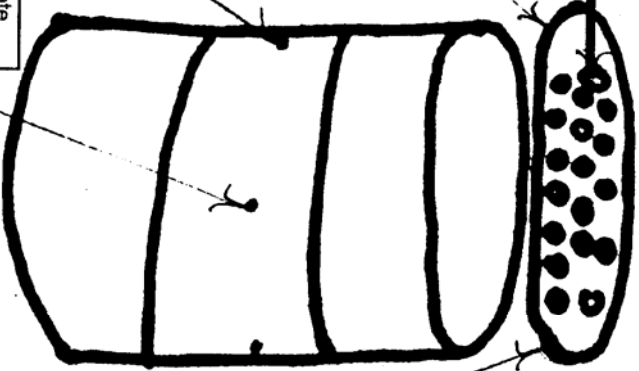

Crate cut from can lid

USE a #10 CAN

HOBO STOVE

Place Grate on top of hangers to hold charcoal for cooking, add charcoal & light.

